



## Cinema Loudspeaker System

### SC-434

#### Features

- 4-way selectable, tri or quad-amplified screen channel system
- Unique HF/VHF diaphragm has less mass than traditional diaphragms resulting in exceptional dynamic range, extended high-frequency response and lower distortion
- LF-4315 is constructed of MDF and features single woofer chambers
- Low-distortion waveguides provide highly articulate dialogue
- Shallow depth (20") facilitates installation
- THX™ approved for professional cinema applications



Developed specifically for the unique requirements of professional motion picture playback, the SC-434 extends QSC's commitment to the cinema market. As a member of the DCS Digital Cinema Speaker Series, the SC-434 is a 4-way, selectable tri or quad-amplified screen channel loudspeaker system comprised of two main units—the MHV-1090 high-frequency system and the LF-4315 low-frequency system.

The MHV-1090 mid-high-very high system features a high output, horn loaded 10" midrange cone driver and a coaxial neodymium high-frequency/very high-frequency compression driver. The MHV-1090 includes a driver protection network and a passive crossover for tri-amp operation. The protection circuitry prevents low-frequency signals from damaging the high-frequency and very high-frequency driver. A high power 10" cone driver allows operation as low as 250 Hz and the advanced phase plug coupling permits a crossover point of up to 1800 Hz to the high-frequency horn. This ensures that most of the dialog range is reproduced by a single element, for unmatched intelligibility.

The coaxial neodymium high-frequency/very high-frequency compression driver provides a dramatic improvement in dynamic response, clarity and transparency. The annular high-frequency diaphragm covers the frequency range between 1800 and 7000 Hz with a smooth, linear response.

The large diaphragm excursion of +/-0.8 mm results in high output and increased power handling. The very high-frequency driver covers the frequency range from 7000 to 22,000 Hz and eliminates the dome break up of conventional drivers that can cause resonance and harsh, metallic sound.

The LF-4315 triple 15" (381 mm) low-frequency enclosure is designed specifically to address the extended low-frequency response required for cinema applications. The LF-4315 covers the frequency range from 35 Hz to 250 Hz. Close Coupled Woofers (CCW), with their tight spacing between woofers, improves coupling and keeps coverage angles wide over a greater frequency range than more widely spaced designs.

The SC-434 is designed for ease of installation. The MHV-1090 components come pre-assembled to reduce field assembly time. Three bolts are all that are required to secure the MHV-1090 to the top of the LF-4315 enclosure.

# SC-434 Details

## Specifications

## SC-434

|   |   |  |  |
|---|---|--|--|
| Nominal Coverage  | 90° horizontal x +20 to -30° vertical   |  |  |
| Frequency Range   | 33 Hz – 16 kHz (-6 dB)  |  |  |
| Crossover Frequency   | 250, 1700 and 6000 Hz, 24 dB per octave   |  |  |
|   | <b>LF-4315</b>  | <b>MHV-1090</b>  |  |
| Impedance   | 5.5Ω  | MF: 8Ω HF: 8Ω VHF: 8Ω  |  |
| Sensitivity 1 watt/1 meter, half space                              | 99.5 dB   | Tri-amp<br>MF: 105 dB<br>HF/VHF: 110 dB  | Quad-amp<br>MF 105 dB<br>HF/VHF: 110 dB<br>VHF: 110 dB |
| Maximum Input Power <sup>1</sup>                                    |   |  |  |
| 8 hours of 6 dB crest factor IEC 268 noise spectrum                 | 1200 W RMS  | MF: 275 W RMS<br>HF/VHF: 230 W RMS   | MF: 275 W RMS<br>HF 150 W RMS<br>VHF: 80 W RMS         |
| 2 hours of 6 dB crest factor pink noise, 50 Hz – 20 kHz, AES method | 1500 W RMS  | MF: 800 W RMS<br>HF/VHF: 500 W RMS maximum   |  |
| Recommended Amplifier Power   | 2400 W RMS maximum  | MF: 800 W RMS<br>HF: 500 W RMS<br>VHF: 300 W RMS maximum   |  |
| Recommended Processing  | Subsonic filter below 30 Hz, > 18 dB per octave   | 4th order LR crossover at 250, 1700 and 6000 Hz via QSC processor  |  |
| Connectors  | Barrier strip screw terminals accept up to #10 AWG stranded wire  |  |  |
| Transducers   | Three 15" (381mm) high efficiency, extended bass woofers featuring 4" copper voice coils  | MF: 10" high-efficiency, horn-loaded cone with phase plug<br>HF/VHF: coaxial neodymium compression driver with 3.5" (90 mm) HF diaphragm and 1.75" (44 mm) VHF diaphragm |  |
| Enclosure   | Quasi B4 alignment, ported enclosure with fully flared ports, symmetrical port design, tuned to 36 Hz, constructed of MDF and heavily braced. Features vandal resistant woofer mounting bolts | Tilt/Pan Bracket<br>±10° vertical tilt<br>±10° horizontal pan  |  |
| Dimensions (HWD)  | 53" x 30" x 20.3" (910 mm x 762 mm x 516 mm)  | 39" x 30" x 20" (990 mm x 762 mm x 508 mm)   |  |
| Weight – Net  | 260 lb (118 kg)   | 84 lb (38.5 kg)  |  |
| System Weight   | 344 lb (155.5 kg)   |  |  |

1) Maximum input power tested in accordance with IEC 268-5 recommendations, 50 Hz – 20 kHz band limiting, 6 dB signal crest factor.

# SC-434 Technical Drawing

Top

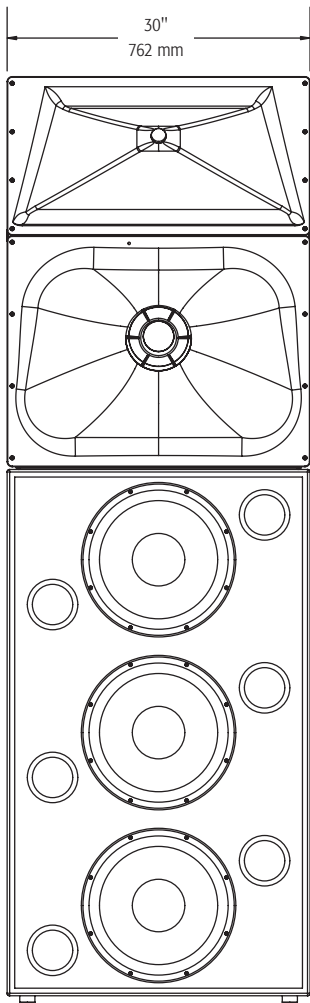
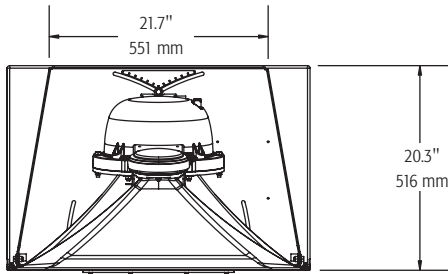

Front

Side

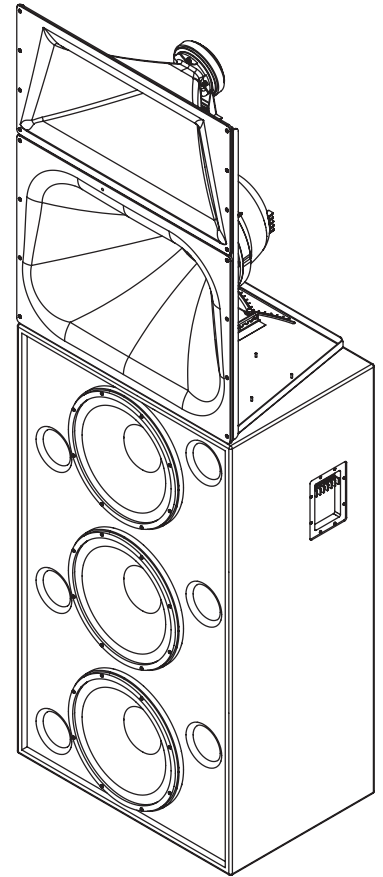
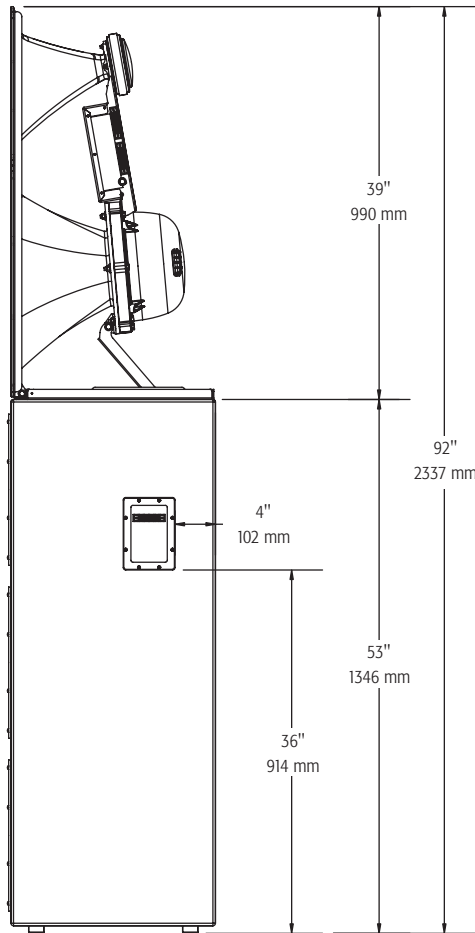

Specifications subject to change without notice.

**QSC**<sup>™</sup>

1675 MacArthur Boulevard • Costa Mesa, CA 92626 • Ph: 800/854-4079 or 714/957-7100 • Fax: 714/754-6174

© 2013 QSC Audio Products, LLC. All rights reserved. QSC and the QSC logo are registered trademarks of QSC Audio Products, LLC in the U.S. Patent and Trademark office and other countries.



please recycle